

CATPHAN[®] 500

This brochure deals with Catphan[®] 500 model, the fifth generation model designed to address specific concerns associated with spiral CT scanners.



Catphan[®] 500

Internationally recognized for measuring the maximum obtainable performance of axial, spiral and multi-slice CT scanners.

Convenient set-up

The Catphan® Phantoms` s patented design includes many exclusive features that makes it easy to achieve perpendicular alignment. As all of the test sections are arranged at prescribed intervals from the first module, operators can quickly scan all test sections in a single sequence, eliminating the need to reposition the phantom for each section. In addition, the integral case mount allows the phantom to be positioned in the scanner, supported off the end of the table, eliminating table artifacts. The case is also equipped with a level to aid in positioning. Fast, easy positioning and the universal mount of the Catphan® Phantom makes it ideal for daily quality assurance programs on any scanner.

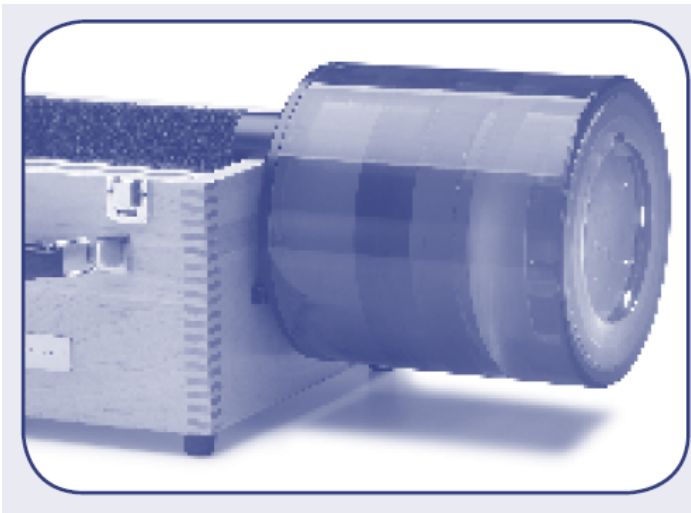

Fast, easy positioning and the universal mount of the Catphan® Phantom makes it ideal for daily quality assurance programs on any scanner.

Solid-cast construction

Catphan® Phantoms are constructed from modules that fit snugly into a durable 20 cm housing. Both the 500 and 600 Catphan® models are made from solid-cast materials, eliminating material absorption of water and leaks associated with water bath phantoms, as well as problems related to varied water sources.

Modular design

The Catphan® modular design allows test modules to be interchanged. As your testing needs change and new modules are developed, you can upgrade test modules that are compatible with your Catphan® system. Additionally, the modular design makes the Catphan® system ideal for travelling physicists and engineers who conduct comprehensive evaluations of CT scanners at multiple locations, as they are easily transportable and no draining is required between uses.

The Catphan® 500 is designed to evaluate the maximum performance potential of axial and spiral CT scanners.

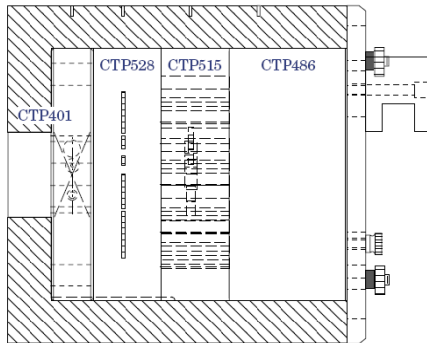

Test Module	500	600
CTP401 module with slice width, pixel size and sensitometry (Teflon, Acrylic, LDPE, Air)	X	
CTP404 module with slice width, pixel size and sensitometry (Teflon, Delrin Acrylic, Polystyrene, H ₂ O, LDPE, PMP, Air)		X
CTP515 low contrast module with supra-slice and subslice contrast targets	X	X
CTP486 image uniformity module	X	X
CTP591 module with slice geometry and point source bead module		X

Stand: 29 May 2008